

FLT - 3P SERIES 220V 100A BATTERY CHARGER UNIT

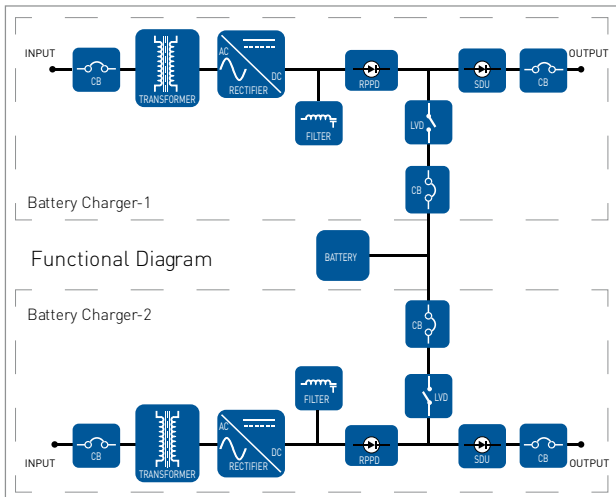

- Production with Single phase and three phase input
- Up to 500 kVA Power range
- Constant voltage and constant current function
- Automatic & Manuel Boost Charge / Float Charge Function
- Full wave rectifying system with Microprocessor controlled thristor units.
- Suitable for charge system for lead-acid & Ni-Cd Batteries
- Low voltage disconnect for Battery discharge protection (LVD)
- Silicon Dropper unit for voltage regulation of DC supply (SDU)
- Designed for heavy duty industrial working conditions
- Reverse polarity protection(RPPD) Distribution CBUS
- Earth leakage protection
- Voltmeter, ammeter



We're Managing Voltage
You're Save Energy

PRODUCT SPECIFICATIONS

WHAT IS BATTERY CHARGER UNIT - RECTIFIER?

FLAT Battery Chargers are produced with microprocessor based boards and have modular structure with its electrical board design. Control and adjustment is realized with thyristor, diode bridges. System has protection system against over current, over voltage, over temperature, short circuit and peak current.

In Flat serial Battery Chargers & Rectifiers an inductor capacitor filter exists at the output. Input and output terminals are in cabinet and protected by suitable fuses.

WHAT ARE THE APPLICATION FIELDS?

FLAT Serial Battery Chargers are designed and produced to be used in communication and alarm circuit of ships and yachts, safety systems in business place and residences, petrochemical industry and power electronics applications, training and test laboratories of schools, test laboratories of factories or feeding system of electronic devices. They are also used for DC feeding system and charge of lead acid, nickel cadmium and dry type batteries. In high discharge currents it provides opportunity to turn on and turn off in short periods. It provides appropriate solutions in emergency illuminating, alarm communication circuits, galvanization and in emergency aluminums eloxal facilities, petro chemistry industry and power electronic practices.



STRUCTURAL SPECIFICATIONS

- Production with single phase and three phase input supply
- Production between range of 12-450 V DC and 1 A-1000 A
- Automatic float boost facility
- High productivity through Thyristor-Diode, Transistor technology and microprocessor controlled boards
- Low waviness (ripple 1%), high current and voltage stability
- User friendly, easy and comprehensible LCD display and mimic diagram
- Audial and lightened warning for all faults and dry contact outputs
- External battery connection
- Battery discharge protection with Low Voltage Disconnect unit (LVD)
- Silicon Dropper unit for voltage regulation of DC supply
- Minimal size, static structure, easy commissioning
- Cabinet design suitable for industrial environment
- Special, durable cabinet, powder coated with standard color named RAL-7035, IP21 (IP54 Optional)
- Manual adjusting property for output voltage and output current from LCD
- Automatic battery activation in case of power cuts (Optional)
- Possibility of regulation of charge-voltage-current through battery temperature feedback (Optional)
- Production with ISO 9001:2008 Quality Management System

TECHNICAL SPECIFICATIONS OF FLT THREE PHASE BATTERY CHARGER UNIT

MODEL	FLT 3P 220V 100A
Power Factor	0,8 (optional 0,9)
INPUT	
Voltage	380 V AC Three Phase + Neutral
Voltage Tolerance	± 15%
Frequency	50Hz ± 5%
Protection	Suitable circuit breaker
OUTPUT	
Nominal Output Voltage	220 VDC
Output Voltage Adjustment	± 20%
Nominal Output Current	100 A
Current Limit Adjustment	5A-100A
Battery Charging System	Automatic constant current / constant voltage control with microprocessor based boards Programmable automatic and manuel BOOST charge - FLOAT Charge control
Battery Type	Nickel-Cadmium (Ni-Cd), Lead Acid, Dry Type
PROTECTION	
Silicon Dropper	Output voltage regulation and restriction for battery charger and power supply circuits applications with "Silicon Dropper"
LVD Unit	Automatic low voltage disconnect units to protect the batteries from deep discharge, (optional)
RPDD Unit	Reverse polarity protection
Automation Unit	Dry contacts for all kind of warnings (optional)
Efficiency	0,9
Crest Factor	3:1
Over Load	0% - 100% load operates continuously, 115% load electronic current limiting
Protection	electronic warning and protection for; high output voltage, low output voltage over temperature and over load, thyristor failure, earth leakage,...etc.
Communication	Dry contact output for all fault and status information
LCD Display	Input voltage, output voltage, output current, battery current, boost charge time and set values for LVD can be seen on LCD display. Additionally; written warnings for over current, over temperature, input failure and general failure (failure record optionally)
Connection	Suitable terminals for input, output, battery and ale art contact
ENVIRONMENTAL CONDITIONS	
Operating Temperature	-10 °C ~ +40 °C (optional cooling units on request)
Altitude	< 3000 m
Humidity	90% none condensed
Acoustic Noise	< 50 dB
CABINET SPECIFICATIONS	
Dimensions (WxDxH) cm	70x70x140
Weight (kg)	300

OPTIONS

OPTION	CODE	DESCRIPTION
Non-standard input voltage value	xxxV	FLT series battery chargers can be produced at any required input voltage value that must be stated clearly by the order confirmation.
Non-standard input voltage range	XS,M,L,XL	FLT series battery chargers can be produced at different input voltage ranges. The required ranges levels must be stated clearly by the order confirmation. Maximum input voltage range: -60%, +40%
Non-standard output voltage value	xxxV	FLT series battery chargers can be produced at any required output voltage value that must be stated clearly by the order confirmation.
Non-standard output voltage tolerance	R	Output voltage tolerances of battery chargers can be +/-1%, +/-2%, -3%, +/-5%.
Adjustable output voltage	ADJ	Output voltage of FLT series battery chargers can be adjusted by the LCD panel. Maximum adjusting range is +/-15%
Non-standard frequency	FRQ	FLT series battery chargers are produced to function under 60 Hz network frequency.
Output protection CB	OCB	Optional CB may be added to the battery charger output to provide additional protection.
Special Enclosure	K	FLT series battery chargers can be produced both INDOOR and OUTDOOR in special cabinets having different IPXX protection classes.
Input/Output EMC Filter	EMC	Specially designed EMC-Filters can be added optionally to the both input and output of FLT series battery chargers. Filter specifications must be stated by offer/order.
Input/Output Surge protector	ESD	High-Voltage Protection and Surge Arrester can be added to the both input and output of FLT series battery chargers. The required protection classes and the specifications (CLASS-I,CLASS-II,CLASS-III) must be given with the order.
Dry contacts	C	NO-NC dry contactor sockets can be applied for ON-OFF and Automatic By-pass modes of the battery charges.
Non-standard Input/Output terminal	T	According to the various customer needs. Input and output terminals can be designed and located specially on the cabinet. The required terminal drawings must be supplied together with the offer/order.
Special design and accessories	SPM	FLT series battery chargers can be designed specially with respect to direct customer needs and technical specifications. All special requirements and detailed technical drawings and specifications for accessories must be provided by the customer at the offer/order stage.
LDV Unit	LVD	Low voltage disconnect for Battery discharge protection.
SDU Unit	SDU	Silicon dropper unit for voltage regulation of DC supply.
Input VM/AM	VM/AM	Analog / digital voltmeter or ammeter for input.
Output VM/AM	VM/AM	Analog / digital voltmeter or ammeter for output.
Battery VM/AM	VM/AM	Analog / digital voltmeter or ammeter for the batteries.
Output Distribution CB	CB	Desired number of distribution CB for output can be applied.
Battery Rack	BR	Battery racks can be installed if required in the order.

NOTES & OPTIONS

- Any optional demands are not included in the prices. Please give in detail the options that you demand.
- All of the optional demands for every model may not be met, please keep in touch with your sales representative for suitable options.
- The technical specifications given in this brochure are to be used as a guide . Edit Elektronik has the right to change without giving prior information. Please contact your sales representative to get the recent information.
- The technical specifications in this brochure are for FLT series battery chargers. Please ask for different models and different technical specifications to your sales representative.
- FLT series battery chargers given in this brochure are easy for installation also in case of need our engineers are ready for help-desk freely.